

SETTLE DOWN IN SETAPAK

Located in Danau Kota, Setapak, one of the prime central districts in KL, Platinum Casa Danau sits in the heart of a relaxed neighbourhood just 20 mins from the city centre. Eateries, schools, medical facilities, shopping malls and LRT stations are nearby while Danau Kota Lake is just 5 mins away. Featuring a low density layout with 200 exclusive units, this project offers comfort, privacy and convenience.

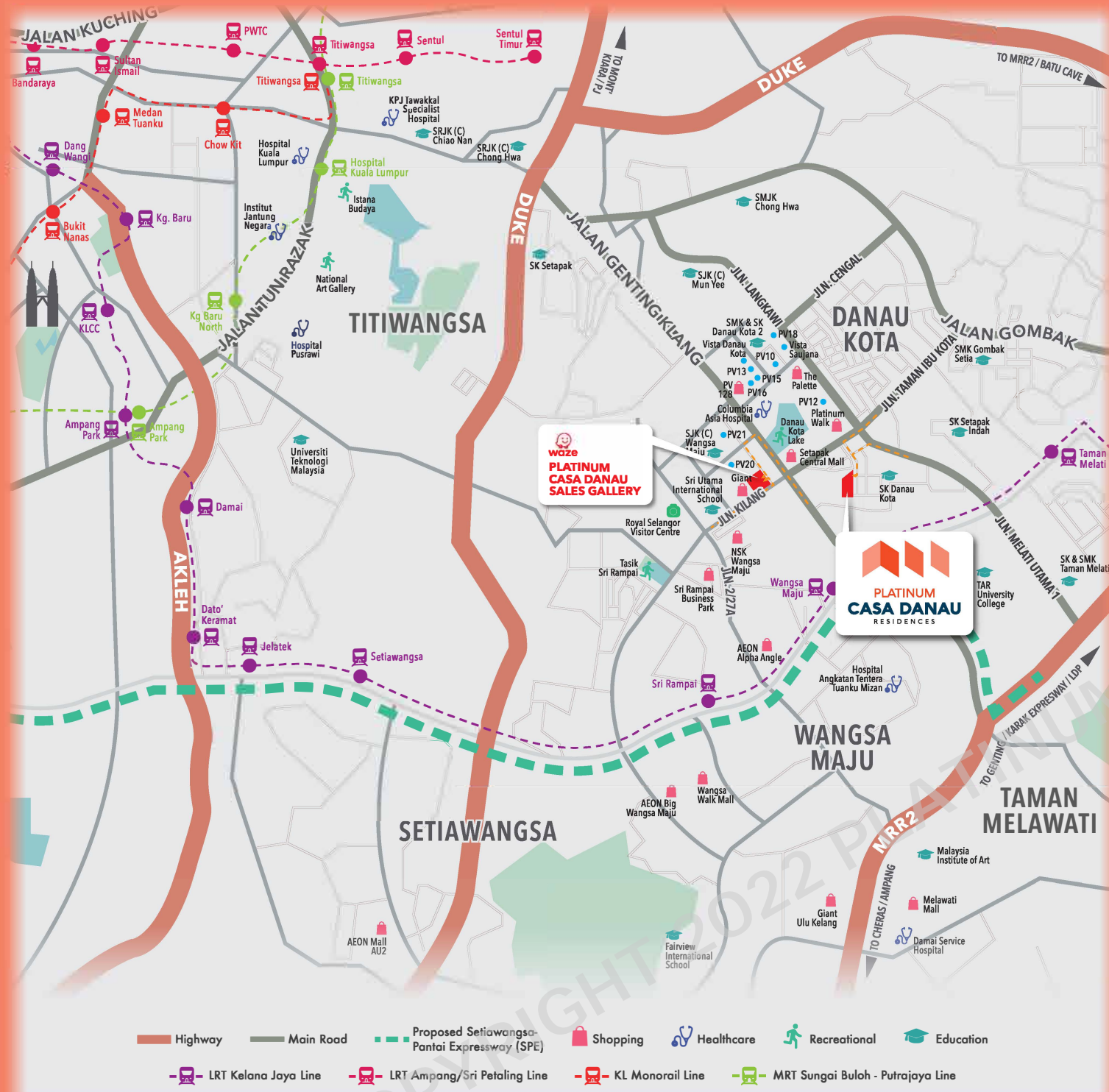

PLATINUM CASA DANAU RESIDENCES

EXCLUSIVITY . LOW DENSITY . PRIVACY
*Limited 200 units only

Call 0111 722 6660

www.platinumvictory.com [platinumvictory](https://www.facebook.com/platinumvictory)
Platinum Victory Development Sdn. Bhd. 667588-x

(A Member Of Platinum Victory)

Galeri PV, No.2, Jalan 3/23a, Setapak, 53000 Kuala Lumpur.

sales@platinumvictory.com



Residensi Danau | Developer Name: Platinum Victory Development Sdn Bhd | Type of Property: Condominium & PPAM | Developer's License No.: 9832-10/03-2024/0150(L) | Validity Period: 02/03/2022 - 01/03/2024 | Advertising Permit No: 9832-10/03-2024/0150(P) | Validity Period: 02/03/2022 - 01/03/2024 | Building Plan Approving Authority: Dewan Bandaraya Kuala Lumpur | Reference No.: BP U2 OSC 2021 0011 (23) | Land Tenure: Leasehold 99 years | Expiry Date: 30 September 2120 | Encumbrances: OCBC Bank (M) Berhad | Expected Date of Completion: March 2025 | Total Units: Block A - Type C: 200 Units; Block B - Type A: 11 Units; Type B: 44 Units; Type C: 136 Units; Type D: 9 units | Selling Price: Block A (min: RM899,000 max: RM747,000); Block B (min: RM48,350 - max: RM300,000) | 5% Discount for Bumiputera (for Condominium only) | This land cannot be transferred, leased, pledged and mortgaged except with the permission of the Land Executive Committee of the Federal Territory of Kuala Lumpur.
THIS ADVERTISEMENT HAS BEEN APPROVED BY MINISTRY OF HOUSING
Disclaimer: All information contained herein is subjected to change as may be required by the relevant authorities without any notification and shall not be binding or be deemed to form a contract or any part thereof. Whilst every care has been taken in providing this information, the developer shall not be held liable for any claims whatsoever arising from the use and/or reliance on the above information. All illustrations and pictures are artist's impressions only, no representation or warranty is made as to the accuracy or completeness of the same. The items are subject to variations, modifications and substitutions as may be recommended by the relevant authorities or consultants. Please refer to the sale and purchase agreement of the actual unit being purchased for specification and description approved by the relevant authorities.

Reference No: PLATINUMCASADANAU(B)/032022/V1



URBAN HOMES FOR AN EXCEPTIONAL LIFESTYLE

Comfort. Accessible. Stylish

Platinum Victory unveils a stunning new high-rise residential in Setapak. Built on two acres, towering above the city, this eye-catching prime property is located in the heart of Kuala Lumpur, just minutes from Danau Kota Lake with scenic views of nature amidst a vibrant urban landscape.

COPYRIGHT 2022 PLATINUM VICTORY. ALL RIGHTS RESERVED.



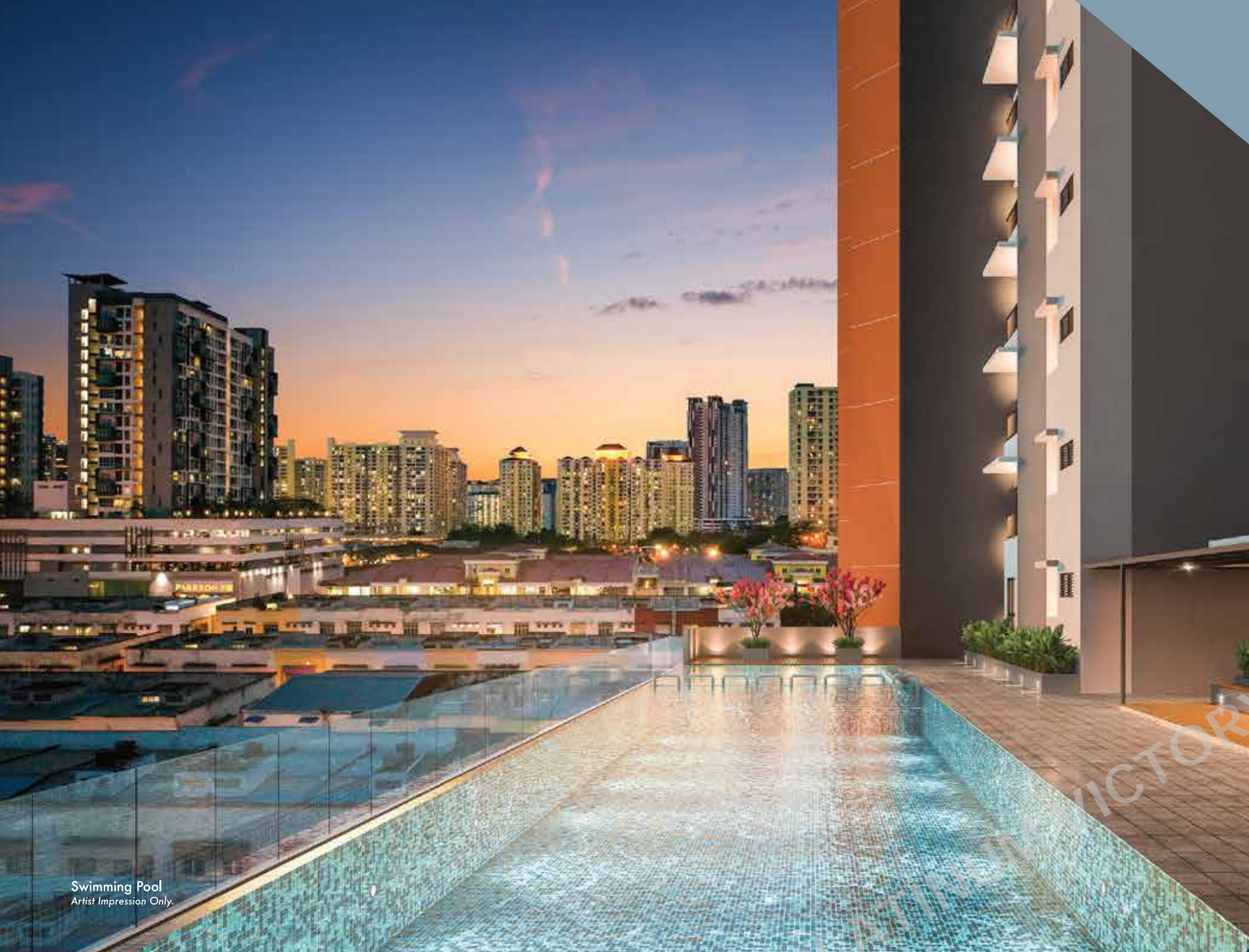

Swimming Pool
Artist Impression Only.

SMART COMMUNITY CURATED

CONVENIENCE AT YOUR FINGERTIPS

Presenting JaGaApp, the all-in-one community solutions platform that allows you to settle maintenance fees, book facilities, engage lifestyle service providers and much more.

Affordability, practicality and convenience are packaged in a smart living bundle, curating a balanced lifestyle meant for Creating Magical Moments.

Innovative Lifestyle with JaGaApp



FACILITIES BOOKING
Reserve your slot anytime, anywhere



EASY PAYMENT
Manage your maintenance fees online



DIGITAL INTERCOM
Your device connects straight to the guardhouse and vice versa



STAY UP TO DATE
Feedback/complaint/notice/happenings



HEY JAGA
Connecting you with qualified professionals, from home services, car care, wellness and beyond



ACCESS CARD SYSTEM
(1ST tier security)



LIFT LOBBY ACCESS
(2ND tier security)



CCTV SURVEILLANCE
(4TH tier security)



LEVEL ACCESS
(3RD tier security)



GUARD PATROL
(5TH tier security)



EMERGENCY ASSIST
Notifies security, family and friends
(6TH tier security)

Safety and Security

WELLNESS & LEISURE



Gym
Artist Impression Only.

Stay active and workout in the comfort of your own home! There are several exercise zones to choose from – outdoor fitness stations on the ground floor or a fully-equipped gym and swimming pool at The Podium on Level 7.



Sky Leisure
Artist Impression Only.

For a spot of leisure, head up to The Rooftop on Level 36. It is the perfect place to catch up with family and friends. Enjoy the ample seating areas and cosy shaded nooks overlooking scenic, sky-high views of the city.

TYPE C/C1



1,184 sq. ft.



3 rooms



2 baths

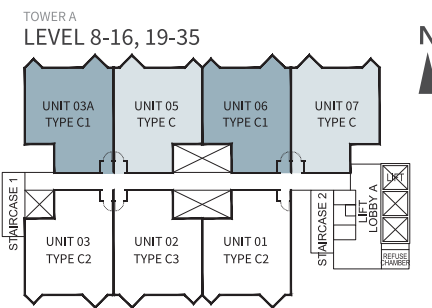

TYPE C1

TYPE C

SPECIFICATIONS

STRUCTURE

Reinforced concrete frame

WALL

Masonry Brick / Concrete / Block / Panel

WALL FINISHES

Ceramic Tiles Kitchen 1500mm Height
All Bathrooms Ceiling Height
Skim Coat & Paint All Other Wall
Paint Finish

FLOOR FINISHES

Ceramic Tiles Foyer / Living / Dining / Bedrooms /
Kitchen / Bathrooms / Yard

DOORS

Timber Door / Plywood Flush Door

WINDOWS

Aluminium Framed Window

IRONMONGERY

Quality locksets

CEILING

Skim Coat & Paint All Ceiling
Plaster Ceiling All Bathrooms

ROOF

Reinforced Concrete Roof /
Metal Decking Roof

SANITARY & PLUMBING FITTINGS

Wash Basin with Tap	2
Water Closet	2
Bib Tap	2
Shower Head	2
Kitchen Sink with Tap	1
Yard Bib Tap	1
Toilet Roll Holder	2

ELECTRICAL INSTALLATION

Lighting Point	18
Fan Point	2
Power Point	17
AC Point	4
Water Heater Point	2
Electrical DB	1
SMATV Point (HD)	2
Door Bell Point	1
Fibre Wall Socket Outlet	1

TYPE C2/C3



1,184 sq. ft.



3 rooms



2 baths

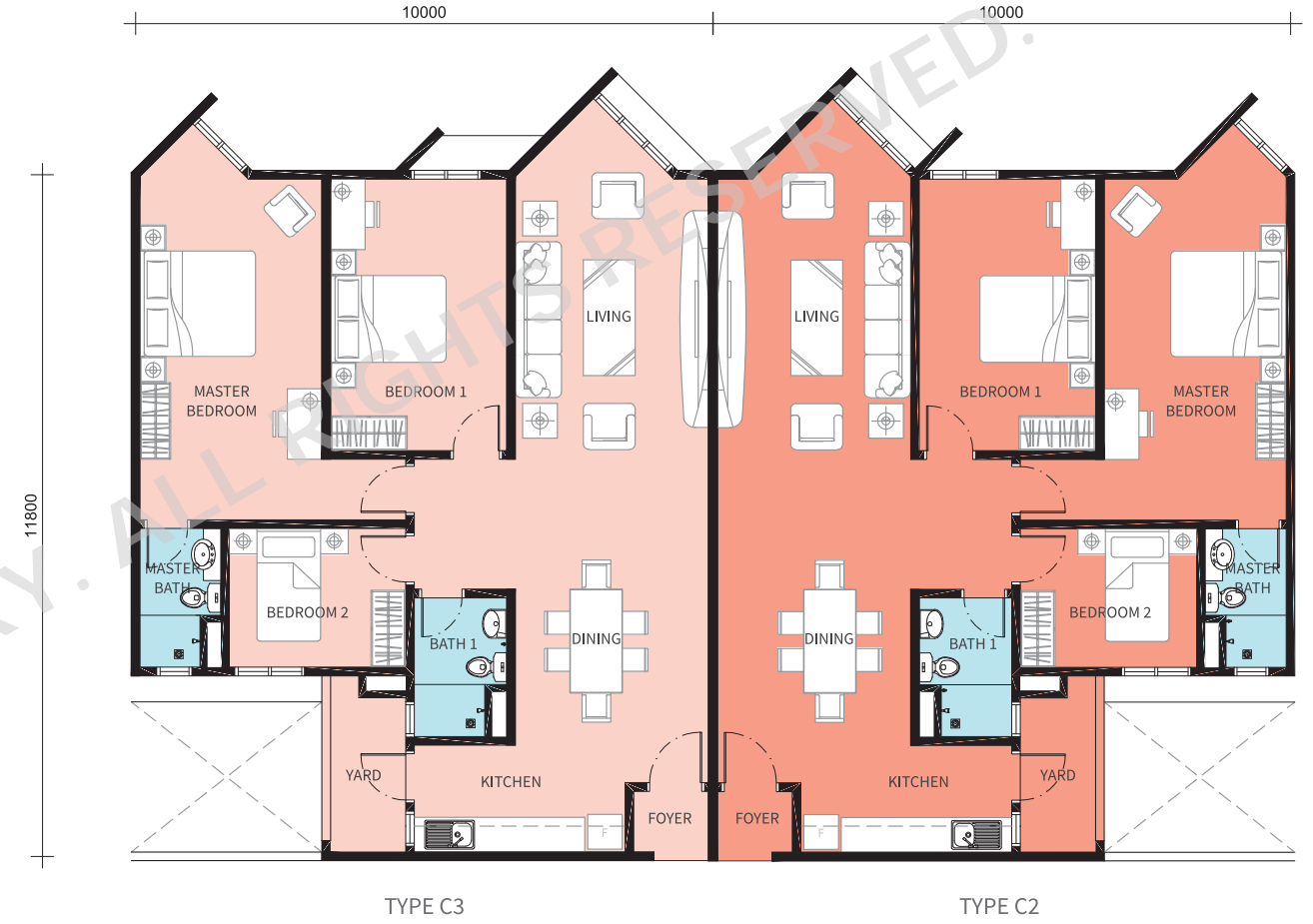
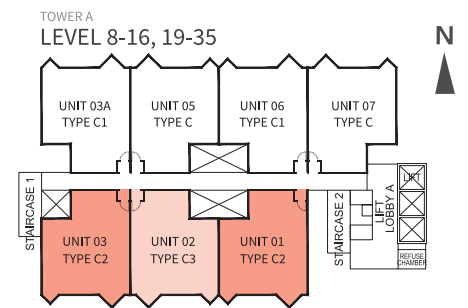

TYPE C3

TYPE C2

SPECIFICATIONS

STRUCTURE

Reinforced concrete frame

WALL

Masonry Brick / Concrete / Block / Panel

WALL FINISHES

Ceramic Tiles Kitchen 1500mm Height
All Bathrooms Ceiling Height
Skim Coat & Paint All Other Wall
Paint Finish

FLOOR FINISHES

Ceramic Tiles Foyer / Living / Dining / Bedrooms /
Kitchen / Bathrooms / Yard

DOORS

Timber Door / Plywood Flush Door

WINDOWS

Aluminium Framed Window

IRONMONGERY

Quality locksets

CEILING

Skim Coat & Paint All Ceiling
Plaster Ceiling All Bathrooms

ROOF

Reinforced Concrete Roof /
Metal Decking Roof

SANITARY & PLUMBING FITTINGS

Wash Basin with Tap	2
Water Closet	2
Bib Tap	2
Shower Head	2
Kitchen Sink with Tap	1
Yard Bib Tap	1
Toilet Roll Holder	2

ELECTRICAL INSTALLATION

Lighting Point	18
Fan Point	2
Power Point	17
AC Point	4
Water Heater Point	2
Electrical DB	1
SMATV Point (HD)	2
Door Bell Point	1
Fibre Wall Socket Outlet	1

THRIVING NEIGHBOURHOOD



Platinum Casa Danau forms part of a vibrant community. Rising high over the city-suburb, it is close to amenities and recreation, easily accessible via major roadways with public transport within walking distance. More than that, it is in a neighbourhood that is alive with excitement, food and leisure, away from the bustle of the city.

Inspired by a sense of community and delivering on quality, make this your home...
Welcome to Platinum Casa Danau.

CONVENIENCE

within 5km, 15 mins away

-  12 Shopping Malls
-  5 Colleges and Universities, 14 Schools
-  2 Hospitals

ACCESSIBILITY

-  3 LRT Stations
-  DUKE Highway, Jalan Genting Kelang, Setiawangsa Pantai Expressway, Middle Ring Road 2

SHOPPING MALLS/ HYPERMARKETS/ COMMERCIAL

- Platinum Walk - 0.7km
- Aeon Big @ The Palette - 0.9km
- Setapak Central Mall - 0.9km
- Giant Hypermarket Setapak - 1.3km
- PV 128 - 1.6km
- NSK Wangsa Maju - 1.8km
- Rampai Business Park - 2.0km
- AEON Mall Alpha Angle - 2.6km
- Wangsa Walk Mall - 4.0km
- KL East Mall - 4.0km
- Melawati Mall - 4.0km
- Aeon Big Wangsa Maju - 4.3km
- Giant Ulu Klang - 6.0km
- Aeon Mall AU2 - 7.1km

TRANSPORTATION

- LRT Taman Melati - 2.0km
- LRT Wangsa Maju - 2.2km
- LRT Sri Rampai - 3.5km

NEARBY RECREATION/ PLACE OF INTEREST

- Danau Kota Lake - 1.6km
- Royal Selangor Visitor Centre - 1.6km
- Tasik Sri Rampai - 2.2km
- Istana Budaya - 5.4km
- National Art Gallery - 5.8km
- Titiwangsa Lake - 7.7km

HOSPITALS

- Columbia Asia Hospital Setapak - 1.5km
- Hospital Antara Tentera - 4.0km
- Tuanku Mizan - 5.6km
- Damai Service Hospital - 5.6km
- KPJ Tawakkal Specialist Hospital - 5.9km
- Hospital Pusrawi - 6.3km
- Institut Jantung Negara - 6.5km
- Hospital Kuala Lumpur - 6.8km

COLLEGE / UNIVERSITIES

- TARUC - 1.7km
- Vocational College Setapak - 2.1km
- Universiti Teknologi Malaysia - 4.8km
- Malaysia Institute Of Art - 4.9km

INTERNATIONAL SCHOOLS

- Sri Utama School - 1.9km
- Fairview International School - 5.8km

PRIMARY SCHOOLS

- SK Danau Kota - 0.3km
- SJKC Wangsa Maju - 1.4km
- SK Setapak Indah - 1.5km
- SK Danau Kota 2 - 1.6km
- SJKC Mun Yee - 2.3km
- SK Taman Setia - 2.8km
- SK Taman Melati - 3.0km
- SJKC Chong Hwa - 4.3km
- SK Setapak - 4.3km
- SJKC Chiao Nan - 4.8km

SECONDARY SCHOOLS

- SMK Danau Kota - 1.6km
- SMK Gombak Setia - 2.3km
- SMK Taman Melati - 3.4km
- SMJK Chong Hwa - 4.0km
- Chong Hwa Independent High School - 9.0km